

**KONOVEN
REX SERIES**

**SPIRAL MIKSER
SPIRAL MIXER**

SPIRALMISCHER

**СПИРАЛЬНЫЙ
СМЕСИТЕЛЬ**



BİLGİ
INFORMATION
ИНФОРМАЦИЯ
INFORMIEREN

REX SERIES

Spiral Mikserler
Spiral Mixers

Spiral mischer
спиральные смесители



Otomatik bıçaksız hareketli spiral mikser KONOVEN kalitesiyle sizlere hamuru yoğururken bıçaksız karıştırma teknolojisi buz kullanım miktarını minimize eder. Kazan miktarının minimum %10'u kadar hamuru rahatlıkla karıştırmakta. Ekranı üzerinden devir ayarı kolaylıkla programlama bilirken hamuru bilgilerini de göstermektedir. Karşılaşılabilecek anlık sorunlar için üzerinde acil stop butonu bulunmaktadır.



Automatischer mobiler Spiralknetter ohne Messer knetet Teig in KONOVEN-Qualität. Die klingelose Mischtechnologie minimiert den Eisverbrauch. Kesselmenge Es mischt leicht mindestens 10% des Teigs. Während die Geschwindigkeitseinstellung einfach auf dem Bildschirm programmiert werden kann, zeigt sie auch die Teiginformationen an. Es hat einen Not-Aus-Knopf für sofortige Probleme.



Automatic bladeless mobile spiral mixer kneads dough with KONOVEN quality. Bladeless mixing technology minimizes the amount of ice usage. Boiler amount It easily mixes at least 10% of the dough. While the speed setting can be programmed easily on the screen, it also shows the dough information. It has an emergency stop button on it for instant problems.



Автоматический безлопастный передвижной спиральный миксер замешивает тесто с качеством КОНОВЕН. Безлопастная технология смешивания сводит к минимуму количество используемого льда. Количество котла Легко замешивает не менее 10% теста. Хотя настройку скорости можно легко запрограммировать на экране, он также отображает информацию о тесте. На нем есть кнопка аварийной остановки для мгновенных проблем.

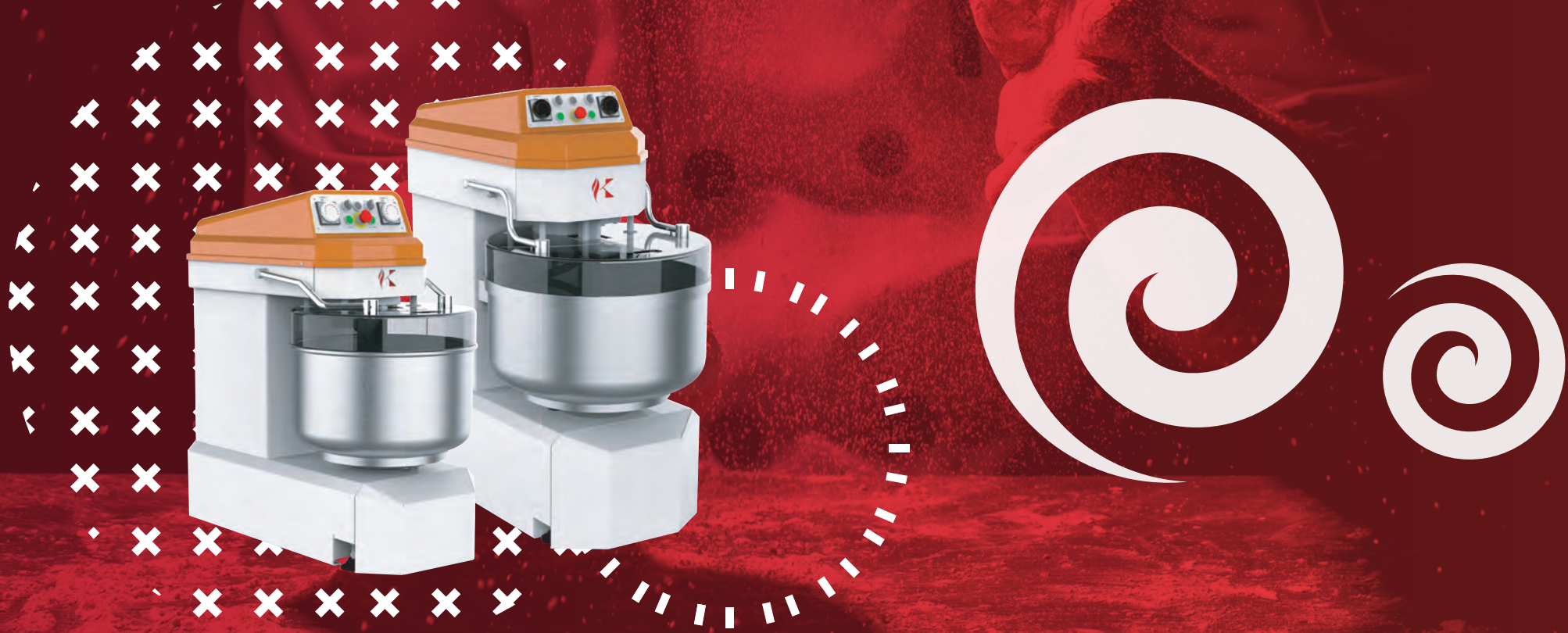

REX-40	1100*1000*580	40	25	535*325	4,2 kw	1kW 940rpm	100-215rpm	3P+N+PE	320
REX-80	1450*1220*730	80	50	700*375	7,1 kw	1,6kW 950rpm	100-215rpm	3P+N+PE	480
REX-100	1100*1220*730	100	60	700*415	7,1 kw			3P+N+PE	580
REX-130	1100*1400*850	130	81	810*420	8 kw		105-215rpm	3P+N+PE	690
REX-160	1100*1480*950	160	103	900*420	9,6 kw			3P+N+PE	750
REX-200	1100*1480*950	200	126	900*480	9,6 kw		100-205rpm	3P+N+PE	755
REX-250	1100*1600*1145	250	150	1000*470	13,6 kw			3P+N+PE	960

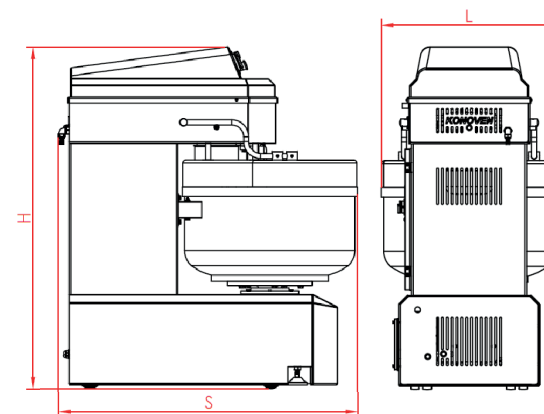

MERKEZ FABRİKA-HEADQUARTERS/FACTORY

Fevziçakmak Mah. Sıla Caddesi

No:46H, 42210 Karatay/Konya

+90 (332) 237 30 30

www.konoven.com

info@konoven.com

ISTANBUL SHOWROOM

Zuhuratbaba Mah. Yüce Tarla Cad.

No:69 D:3 Bakırköy/İstanbul/TÜRKİYE

Zorman Kurumsal Gıda Mak. Ltd. Şti.

+90 (532) 012 35 74

+90 (536) 617 24 58

zorman@zorman.com.tr

+90 (212) 877 35 42

www.zorman.com.tr



www.konoven.com

konoven /     

